

# Oilgear Pumps: Built for Pressure, Engineered for Endurance

## Every Hydraulic System Depends on One Thing: Staying Alive Under Pressure

Every hydraulic system is only as strong as its pump. Whether it's powering a die-cast press, a test stand, or an automated fixture, true performance comes from the ability to generate consistent pressure without drift, failure, or costly downtime.

For that kind of reliability, you need a pump built to take abuse, shrug off contamination, and deliver precise control under pressure. **That's where Oilgear stands apart.**

Oilgear pumps are known for one thing above all: **rugged performance in harsh environments.**

The PVWJ, PVG, PVV, and XD5 series are designed from the ground up for efficiency, stability, and long life, combining compact, configurable frames with advanced control options and exceptional serviceability.

Oilgear pumps deliver efficient, stable performance with the **lowest total cost of ownership.**



**OILGEAR**

## Hard-on-Hard Technology, Designing Better Pumps from the Ground Up

Instead of traditional bronze bushings or roller bearings, Oilgear uses **hardened steel running directly on hardened steel.** **This metallurgical** pairing forms a **hydrodynamic film of oil** between surfaces, with no mechanical contact, no friction wear.

This **“hard-on-hard”** design means:

- ➔ Superior tolerance to dirty or water-based fluids
- ➔ No soft metals to gall, score, or seize under contamination
- ➔ Predictable, repeatable performance for decades

Oilgear pumps don't fail because of something soft wearing out.

“Hard-On-Hard” Technology

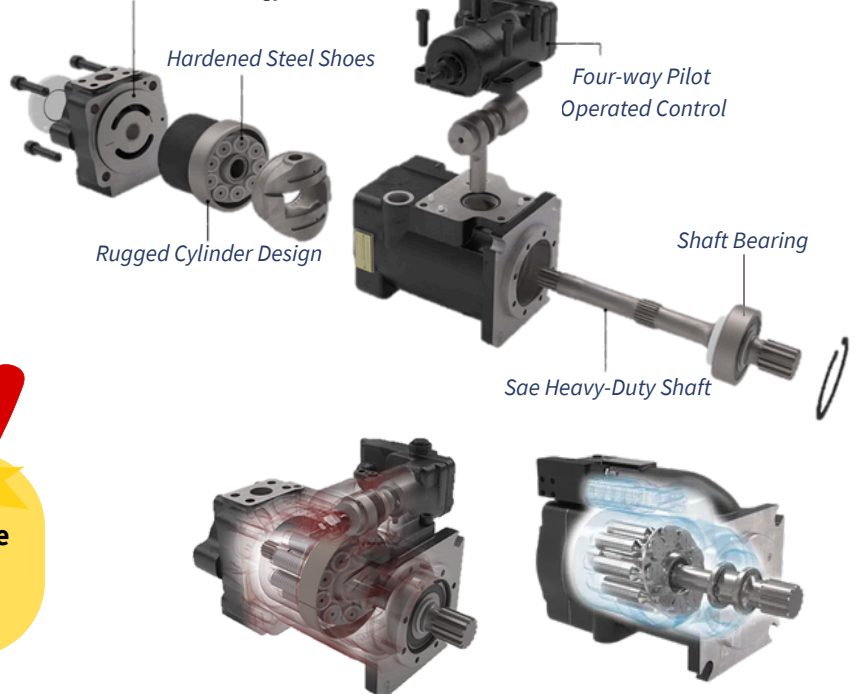

### PVWJ & PVG FUN FACT:

15+ compensation units, including:

1. **Power Limiter w/ Adjustable Load Sense**
2. **Remote Digital Pressure Control**
3. **Remote Proportional Pressure Control**

## No Rear Bearing. No Problem.

Unlike most axial piston designs, the Oilgear rotating group doesn't need a rear support bearing.

The rotating assembly is perfectly balanced around the oversized shaft bearing, swashplate, and supported entirely by hydraulic pressure, not by internal rolling elements.

This patented geometry keeps the pump stable, smooth, and self-supporting even under high side loads or rapid cycling. It's one of the reasons Oilgear systems stay in service for 30+ years with minimal internal wear.

- 5.No Rear Support Bearing Required
- 8.Special Polymerous Saddle Bearings
- 9.Patented Pressure Lubricated Swashblock Design
- 10.Sealed Front **Shaft Bearing**
- 12.Hydrodynamic Bearing

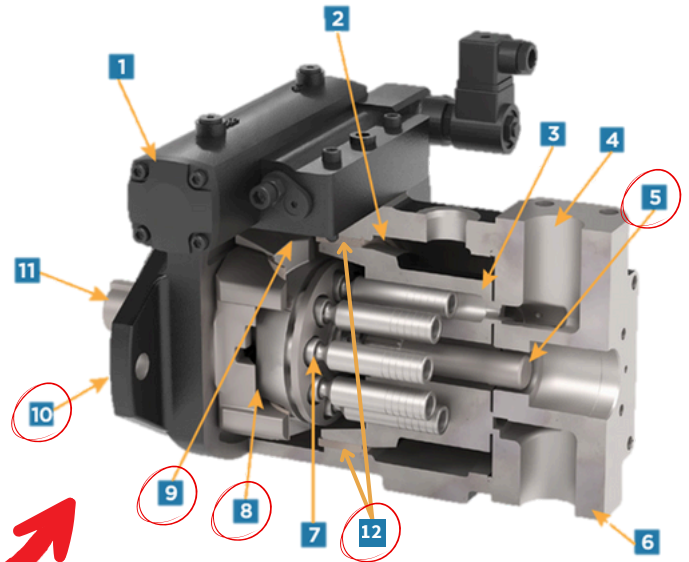

Curious what the other pump features are?  
Email us today: [sales@donaldengineering.com](mailto:sales@donaldengineering.com).

This bearing design fundamentally allows us to run different fluid viscosities.

### Simplified Maintenance!

**Oilgear pumps are easy to service.**

Replace the shaft without opening the pump!



## Hydrodynamic Bearings Mean No Limits

Because the bearing system has no internal rotating elements, it can run on extremely low viscosity fluids. Oilgear pumps can run confidently on fluids where other pumps struggle, from skydrol and water glycol to high-viscosity oils and specialty synthetics.

The sealed front bearing isolates the drive end from the hydraulic fluid, while the pressure-lubricated internals maintain film strength across all conditions. That's why these pumps are trusted in everything from aerospace test rigs to heavy industrial presses.

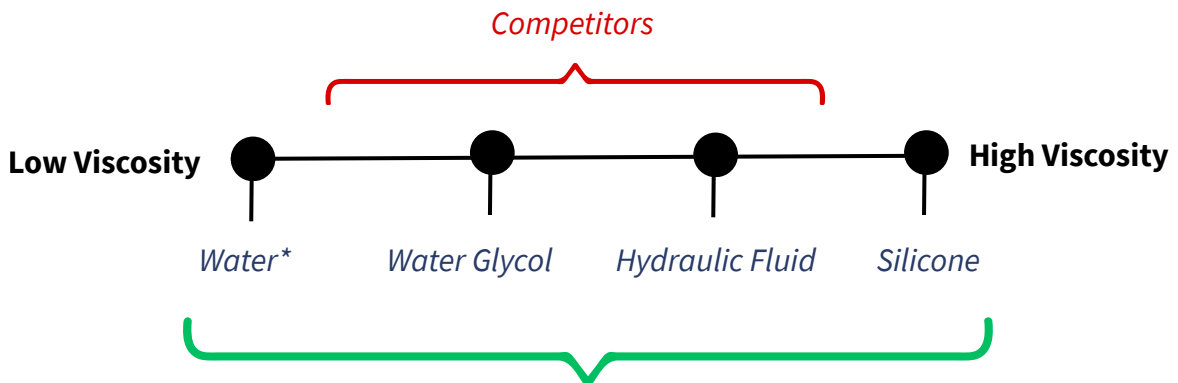

*\*Water & brake fluid are difficult fluids with low lubricity but we can pump them!*





**PVWJ**

**PVG**

**PVV**

**XD5**

Easy to service, economical, versatile control flexibility, tandem configurations  
**Flow Range:** 1-60 GPM  
**Pressure:** 2,500- 5,000 psi  
**Peak Pressure:** 5,800 psi  
**Displacement Options:** .66 – 8.0 cu in<sup>3</sup>/rev  
**Primary Application:** Industrial systems, test stands, presses



Built in the USA!

Fast response, fast compensation, tandem capability  
**Flow Range:** 21-83 GPM  
**Pressure:** 3,750 - 5,000 psi  
**Peak Pressure:** 5,800 psi  
**Displacement Options:** 1.3 – 10.9 cu in<sup>3</sup>/rev  
**Primary Application:** Fast medium flow & tandem systems



Built in the USA!

Maximum flow & efficiency  
**Flow Range:** 72 – 171 GPM  
**Pressure:** 5,000 psi  
**Peak Pressure:** 5,800 psi  
**Displacement Options:** 9 – 23+ cu in<sup>3</sup>/rev  
**Primary Application:** High-performance systems, large flow



Built in the USA!

High power density, lightweight footprint  
**Flow Range:** 22 – 71 GPM  
**Pressure:** 5,000 psi  
**Peak Pressure:** 5,800 psi  
**Displacement Options:** 3.05-9.16 cu in<sup>3</sup>/rev  
**Primary Application:** Mobile or compact industrial applications. Narrow build to stack on P.T.O.



Built in the USA!

## The Donald Engineering Difference

Component

or

Component + Consultation

or

Custom Solution

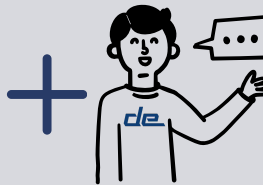

Our engineers apply decades of system experience to build and support power units, manifolds, and machine upgrades that make the most of Oilgear's performance advantages. We stock common PVWJ and PVG models for faster turnaround, provide local service and support, and back it with real engineering expertise.

### Ready to Upgrade Your System?

If your hydraulic systems are running 24/7 and downtime isn't an option, it's time to take a closer look at Oilgear. From component supply to complete hydraulic design, Donald Engineering is your partner in building systems that perform under pressure.

Talk to a DE Sales Engineer today!



[sales@donaldengineering.com](mailto:sales@donaldengineering.com)



(616) 538-8340

